

Version
01.00November
2003

WLAN Protocol Tester R&S® PTW 70

IEEE 802.11 multimode protocol tester for development, integration and verification

Applications

- ◆ Development – The R&S® PTW 70 is an indispensable error diagnostics tool for wireless LAN system components from chip set to complete infrastructure
- ◆ Integration – By accommodating wireless LAN software and hardware modules, the R&S® PTW 70 can be used to evaluate how different system components interact and to test cross-technology compatibility
- ◆ Verification – Due to its special design, the R&S® PTW 70 allows the performance and quality features of wireless LAN system components to be objectively evaluated for the first time

Features

- ◆ Analyzer mode – The IEEE 802.11 reference model of the R&S® PTW 70 simulates a wireless LAN access point or a station
- ◆ Sniffer or monitor mode – The R&S® PTW 70 records data communications in a wireless LAN cell
- ◆ The multi-choice operating concept features graphical and programmable user interfaces
- ◆ Online analysis tools provide the user with reliable data exactly when needed
- ◆ Hardware-based timers and realtime processing make it possible to analyze protocol sequences in detail in all operating modes
- ◆ The measurement unit is detached from the controller and can be remotely driven from different workstations
- ◆ The modular design allows flexible tester configurations specific to a given measurement task – from the single-channel model to versions networking several R&S® PTW 70 testers
- ◆ Its predefined set of applications is tailored to specific user groups
- ◆ Its powerful hardware platform makes the tester a future-proof investment



ROHDE & SCHWARZ

Objective of the R&S® PTW70

The WLAN Protocol Tester R&S®PTW 70 represents a considerable enhancement in speed, accuracy and cost-effectiveness in the complex measurement tasks involved in multi-standard wireless LAN systems.

Target customers

- ◆ Innovators in wireless LAN chip-set and protocol-stack development
- ◆ Suppliers of wireless LAN system components and infrastructures
- ◆ Consulting firms and engineers specializing in radiocommunications and telecommunication systems
- ◆ Professional providers and users of WLAN-based services and networks
- ◆ Laboratories and test houses performing interoperability, compatibility and certification tests

What does IEEE 802.11 multimode protocol tester mean?

IEEE 802.11 currently specifies wireless LAN systems for the 2.4 GHz ISM frequency band (802.11b and 802.11g) and the 5 GHz U-NII frequency band (802.11a).

The R&S®PTW 70 supports the 802.11a and 802.11g systems, i.e. it offers a wide range of functions from the RF frontend, the physical protocol layer, the MAC protocol layer through to applications. As to 802.11b functionality, the focus

IEEE Standard		R&S® PTW 70 availability	Comments
802.11a	PHY/MAC layers for high-speed WLAN in 5 GHz frequency band	●	
802.11b	PHY/MAC layers for WLAN in 2.4 GHz frequency band	○	Sniffer mode and 2.4 GHz interoperability testing
802.11c	MAC layer procedures to cover bridge operation with 802.11	○	Please ask about availability
802.11d	PHY layer requirements to extend the operations of 802.11 to new regulatory domains	●	
802.11e	MAC layer enhancement to improve and manage QoS	●	See application note for further details
802.11f	Inter-access point protocol to support multi-vendor AP interoperability across a DS	○	Please ask about availability
802.11g	PHY/MAC layers for high-speed WLAN in 2.4 GHz frequency band	○	Mandatory parts are implemented
802.11h	PHY/MAC layer enhancement (DFS/TPC)	●	See application note for further details
802.11i	MAC layer enhancement to improve security and authentication mechanisms	●	See application note for further details
802.11j	PHY/MAC layer enhancement to apply the Japanese rules for radio operation in 4.9 GHz and 5 GHz bands	○	Please ask about availability
802.11k	Radio resource measurement enhancements provide interfaces to higher layers for radio and network measurements	○	Please ask about availability

Table 1: IEEE 802.11 standards versus R&S®PTW70 implementation (as of October 2003).

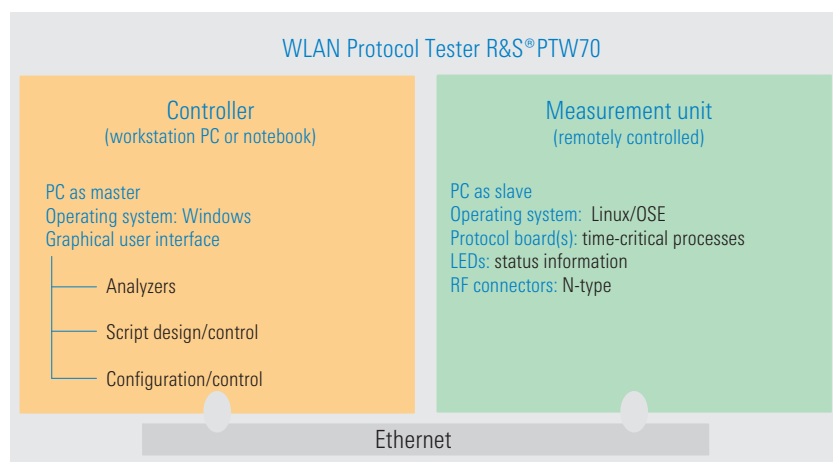

Fig.1: Design of WLAN Protocol Tester R&S® PTW70

is on interoperability measurements, particularly the monitor mode and analysis functions for testing 802.11b and 802.11g interoperability. IEEE 802.11 defines a number of additional functions for the PHY and MAC protocol layers. These functions and their implementation in the R&S® PTW 70 are listed in Table 1.

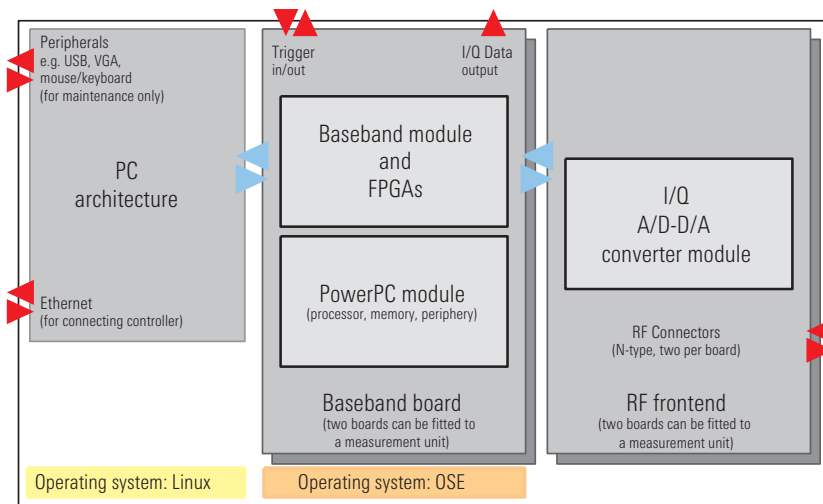

Fig. 2: R&S® PTW70 modules.

Modular design

The WLAN Protocol Tester R&S® PTW 70 (see Fig. 1) consists of a measurement unit and a controller (workstation PC or notebook). The two components are connected via Ethernet directly or as part of a network. The detached measurement unit of the R&S® PTW 70 can be configured and monitored via a graphical user interface. The measurement data is returned to the controller and can be evaluated conveniently using graphical analysis tools. In addition, complex test sequences can be configured via a user-friendly

graphical script interface and run by remote control. The measurement unit contains a wireless LAN protocol plug-in developed by Rohde & Schwarz. The plug-in consists of an RF frontend capable of multi-frequency-band operation and a processor architecture suitable for all time-critical wireless LAN protocol processes. The measurement unit can be equipped with one or two protocol plug-ins. Moreover, several measurement units can be networked. This modular concept is also employed in the software, thus opening up a wide

range of sophisticated measurement applications. Table 2 shows the different configuration levels and corresponding applications of the WLAN Protocol Tester R&S® PTW 70.

Measurement unit

Fig. 2 provides a schematic view of the modules of the R&S® PTW 70 measurement unit.

Using a standard PC architecture, the R&S® PTW 70 measurement unit can simultaneously carry out measurements, record measured data and, in the background, send the data to the detached controller. The baseband architecture is oriented to the realtime requirements of the PHY layer and the MAC layer. The baseband board is designed to support future requirements of the WLAN standards by installing software updates. The RF frontend covers the currently used frequency spectrum for WLAN systems. The RF frontend can be set to receive selected frequency bands or channel bandwidths to match the internal settings of the mixer stages or external devices that are connected.

R&S® PTW 70 measurment unit (number)	R&S® PTW 70 protocol plug-in (number)	Configuration (R&S® PTW 70)	Configuration (DUT)
one	one	Analyzer mode – one access point	Station
		Analyzer mode – one station	Access point
		Monitor mode	Communication between components
		Monitor mode and test station	
	two	Analyzer mode – two access points (single band/dual band)	Station
		Analyzer mode – two stations (single band/dual band)	Access point
		Analyzer mode – one access point and one station	Communication between components
		Analyzer and monitor mode	
Several	one to two	As needed	

Table 2: Scaling of WLAN Protocol Tester R&S® PTW 70.

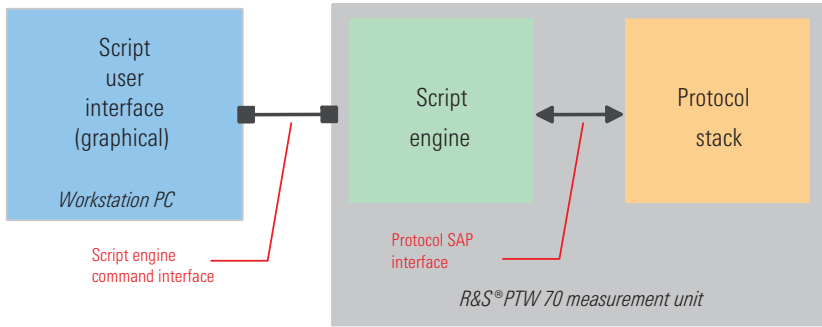

Fig. 3: R&S® PTW 70 programming environment.

Featuring trigger signal inputs and outputs, an I/Q output and configurable RF connectors, the R&S® PTW 70 measurement unit can easily be integrated into more complex test setups.

Software concept

The R&S® PTW 70 uses three operating systems. All time-critical processes run on the OSE realtime operating system and are executed by accessing a reliable Rohde & Schwarz protocol stack model. The PC of the measurement unit runs on the Linux operating system, which is also used to communicate with the controller. The user interface is designed for 32-bit Microsoft Windows operating systems.

Three tools are available to enable optimal configuration of the R&S® PTW 70 for a given measurement task (see Fig. 3).

The user interface consists of the following elements:

- ◆ Graphical script editor: the direct way to measurement results
- ◆ Script-based programming interface: time-saving in automatic tests
- ◆ C++ library: error simulation for quality assurance at all stages of development

The graphical script editor (see Fig. 4, background) is installed on the controller. Featuring a predefined set of control commands and 802.11-specific protocol vocabulary, the editor supports the fast and guided generation of test scenarios. The graphical user interface is a very convenient means of setting variables and protocol parameters as well as branching to program sections or repeating selected sequences.

Test scenarios can also be created as texts through direct access to the script engine command interface (see Fig. 3) (feature currently in the planning stage).

The measurement unit processes both graphical and text scripts. With no more than a mouseclick, the scripts are available for processing after going through an executability check.

The protocol SAP interface (see Fig. 3) provides unrestricted access to the R&S® PTW 70 protocol stack. The interface, which is implemented as a C++ library, enables the user to manipulate the time sequence of events, modify baseband processes (for example by changing the header or checksum of a protocol message) and insert test sequences.

Abbreviation	Meaning
AP	Access point
DFS	Dynamic frequency selection
DUT	Device under test
IEEE	Institute of Electrical and Electronic Engineers
ISM band	Industrial-Scientific-Medical band
LAN	Local area network
MAC layer	Medium access control layer
PHY layer	Physical layer
QoS	Quality of service
RF	Radio frequency
SAP	Service access point
STA	Station
TPC	Transmit power control
U-NII band	Unlicensed National Information Infrastructure band
WLAN	Wireless LAN

Table 3: Abbreviations.

The graphical analyzer (see Fig. 4, foreground) displays the protocol-based communication between the DUT and the R&S® PTW 70 in detail and with high time resolution. Analysis is facilitated by various protocol views displaying, for example, a decoded protocol message in detail, a single protocol layer, or a complete protocol sequence. In addition, an extensive range of filter and event functions is available to support systematic fault and error analysis and correction.

Since it supports controlled error simulation in the protocol sequence, manipulation of test sequences, realtime analysis and complete documentation of results, the WLAN Protocol Tester R&S®

PTW 70 is an indispensable tool in the development, integration and verification of wireless LAN systems.

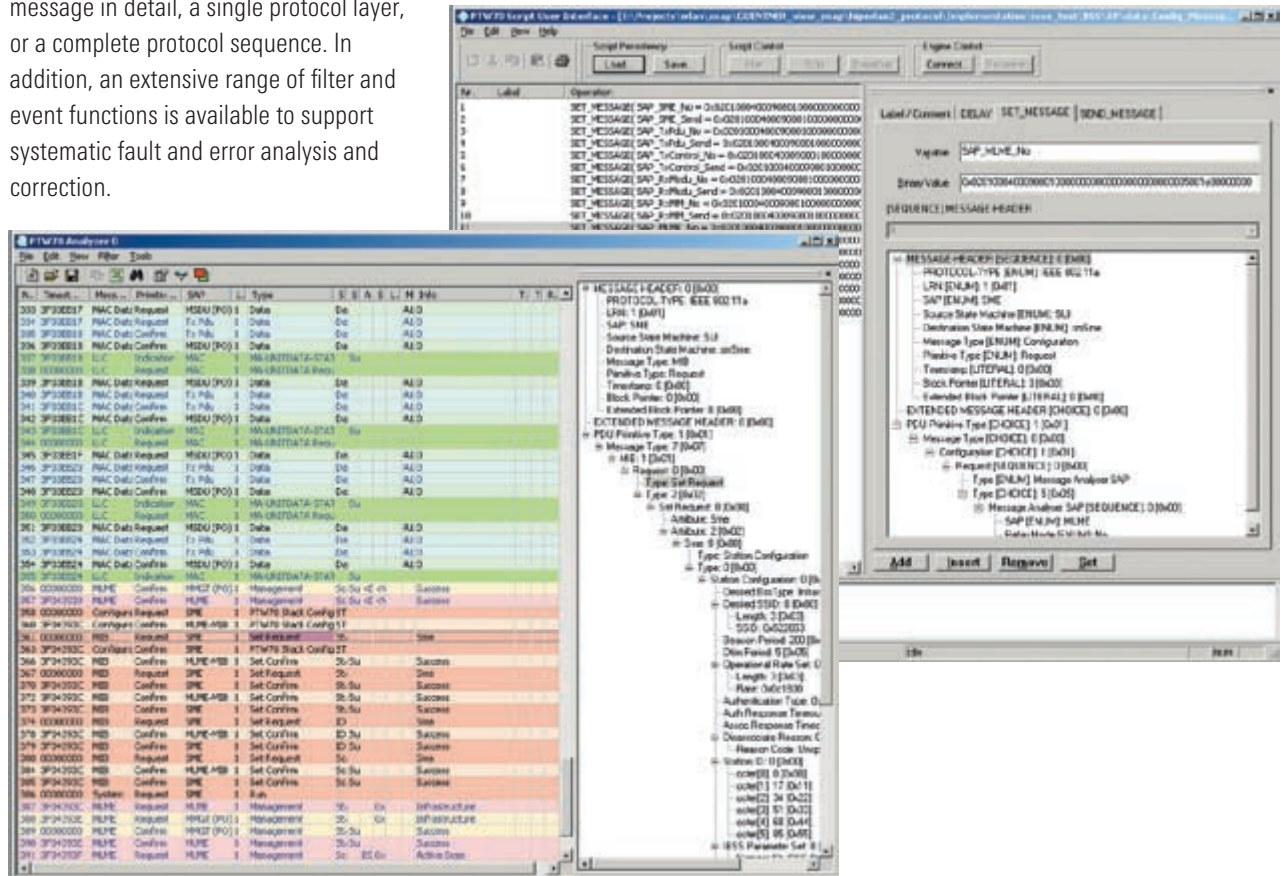

Fig. 4: R&S® PTW 70 graphical script editor and analyzer.

Specifications

TX/RX (RF)		
Frequency range	Band 1 IEEE802.11b	2400 MHz to 2500 MHz
	Band Japan IEEE802.11a	4910 MHz to 5080 MHz
Frequency resolution	Band 2 IEEE802.11a	5150 MHz to 5350 MHz
	Band 3 EU HiperLAN2	5470 MHz to 5725 MHz
	Band 3 US IEEE802.11a	5725 MHz to 5825 MHz
Frequency accuracy	internal reference	5 × 10 ⁻⁶

TX		
Modulation		
EVM	P _{out} = 0 dBm	>28 dBm
Spurious	10 kHz to 200 MHz offset	-40 dBc
	>200 MHz offset	-20 dBc
Harmonics	2nd and 3rd order	-30 dBc
Output level		
Max.		+6 dBm
Range		20 dB
Resolution		1 dB

Output level accuracy		
Frequency response	Band 1 Band 2, 3	1 dB 2 dB
Temperature drift	+5 °C to +45 °C +20 °C to +30 °C	2 dB 1 dB
Repeatability		0.1 dB
Output VSWR		<2 : 1
RX		
Immunity to interference		
Image rejection		>30 dB
IF rejection	IF1: 1150 MHz IF2: 20 MHz	>30 dB >50 dB
Sensitivity	packet error rate PER: 10 % According to S/N	-82 dBm at 6 Mbit/s (~S/N = 12 dB) -65 dBm at 54 Mbit (~S/N = 29 dB)
Max. input level		-30 dBm
Level accuracy		
RF frequency response	Band 1 Band 2, 3	1 dB 2 dB
Drift	+5 °C to +45 °C +20 °C to +30 °C	2 dB 1 dB
Repeatability		0.1 dB
Input VSWR		<2 : 1

RF interfaces	
Split RF connectors for antenna diversity with N connectors at front panel	
External reference inputs/outputs with BNC connectors at rear panel	
Digital interfaces	LAN 100BT
	dual-port USB connector for LAN setup
	VGA connector for external monitor for LAN setup
Environmental requirements	
Operating temperature range	+5 °C to +45 °C according to DIN EN 60068-2-30: 2000-02
Storage temperature range	-25 °C to +60 °C according to DIN EN 60068-2-30: 2000-02
Relative humidity	+40 °C 95 % noncondensing according to DIN EN 60068-2-30: 2000-02
Mechanical resistance	
Vibration, sinusoidal	5 Hz to 150 Hz according to DIN EN 60068-2-6: 1996-05
Vibration, random	5 Hz to 300 Hz according to DIN EN 60068-2-64: 1995-08
Shock	40 g shock spectrum according to DIN EN 60068-2-27: 1995-03
General data	
Power supply input range	100 V to 240 V AC
Power supply input power	max. 310 VA
Power supply frequency range	50 Hz to 60 Hz
Regulatory requirements	
Electromagnetic compatibility in line with EMC directive of EU	
EMC standards met	DIN EN 61000-6-3 and DIN EN 61000-6-4
Safety standards met	EN 60950 (1992 + A1 2993 + A2 1993 + A3 1995)
Mechanical data	
Dimensions (W × H × D)	310 mm × 140 mm × 430 mm
Weight	10 kg

Printed in Germany
(P e as)

R&S® is a registered trademark of Rohde&Schwarz GmbH & Co. KG. Trade names are trademarks of the owners. Subject to change
PD 0756.0288.32 • WLAN Protocol Tester R&S® PTW70 • Version 01.00 • November 2003 • Data without tolerance limits is not binding

For detailed ordering information please contact your local Rohde & Schwarz representative.



ROHDE & SCHWARZ